

Product Specification Sheet

Product name – MKII HGV Wheel Stop

Product code *Model*
P-747350 MKII HGV Wheel Stop



Manufacturer / Brand	GH Pittman
Warranty	1 Year manufacturer's warranty
Material	100% rubber
Components	Rubber wheel stop with moulded reflective strip
Dimensions	935(L) x 280(W) x 150(H)mm
Weight	25kg
Features	Full rubber design – excellent durability for long term use 3M moulded reflective strips – long-lasting visibility Use with trucks, vans, lorries and more Fixings included with each kerb Gripped design on rear of wheel stop reduces risk of stranded vehicles
Fixings	5no. 145 x 10mm coachscrews with matching rawlplug

Ireland:
B2 Athy Business Campus
Athy, Co. Kildare R14 PK74
Ph: 01 531 2777
Email: sales@pittman.ie

United Kingdom:
1310 Solihull Parkway, Birmingham Business Park
Birmingham B37 7YB
Ph: 0121 630 3527
sales@pittman.uk

Technical Specifications

PARAMETERS	VALUE	UNIT	METHOD
Tensile strength	$\geq 1,0$	MPa	PN-ISO 37
Hardness	≥ 55	°Sh	PN-EN ISO 868:2005
Tolerance dimension - length	± 20	mm	from the nominal
Tolerance dimension - width	± 10	mm	from the nominal
Tolerance dimension - height	± 5	mm	from the nominal

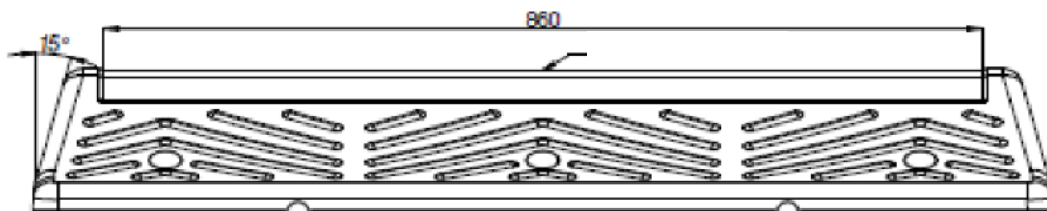
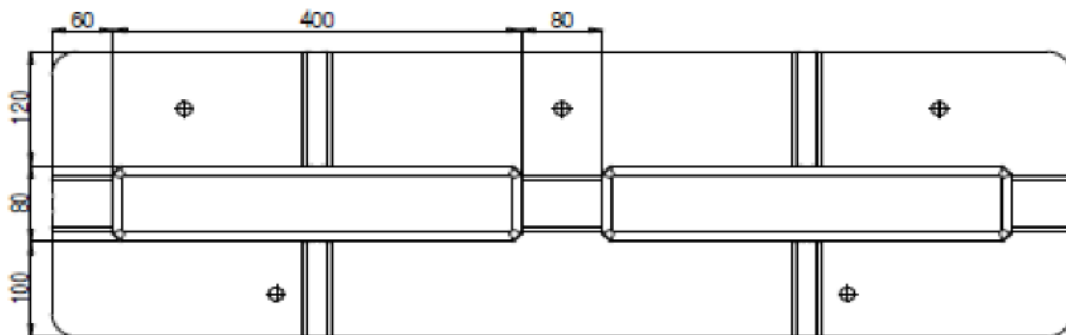
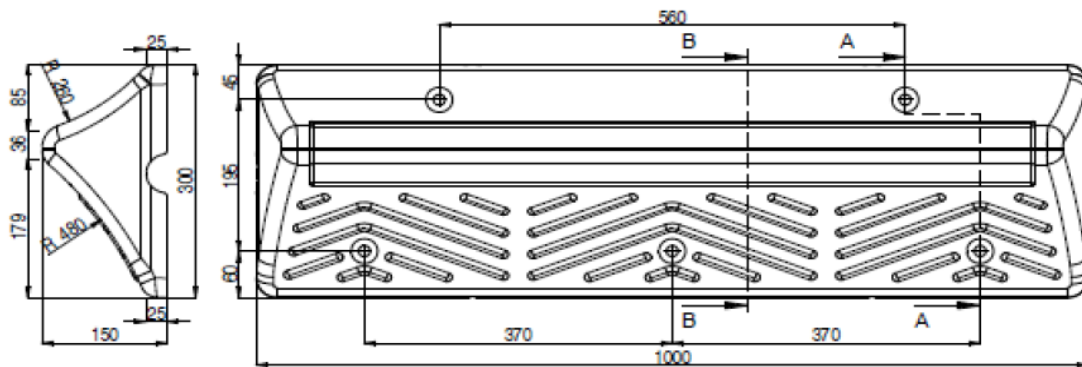

Ireland:
 B2 Athy Business Campus
 Athy, Co. Kildare R14 PK74
 Ph: 01 531 2777
 Email: sales@pittman.ie

United Kingdom:
 1310 Solihull Parkway, Birmingham Business Park
 Birmingham B37 7YB
 Ph: 0121 630 3527
sales@pittman.uk